

Saildrive Engine Range - Specifications

2, 3 or 4 cylinders with high inertia flywheel for smooth running at low rpm.

Heater plugs for cold starting below 5°C, fuel filter, **MECHANICAL** fuel lift pump, **MECHANICAL** fuel injection pump and **MECHANICAL** engine governing ensures steadfast performance regardless of ambient conditions.

QUIET GEAR DRIVEN CAMSHAFT for maximum engine reliability and reduced servicing, as no timing chains or toothed belts have to be replaced.

Subject to criteria, Kubota based engines accommodate installation angles up to 15° maximum when static and 25° when heeling.

The Beta 14, 16, 20 & 25 are equipped with a standard 40 Amp alternator, the Beta 30, 38 & 45T are equipped with a standard 70 Amp alternator all are driven by a polyvee belt/pulley.

The Beta 43, 50 & 60 are equipped with a standard 70 Amp alternator, driven by an "A" section profiled belt/pulley. **OPTIONAL OR ADDITIONAL ALTERNATORS** & polyvee belt/pulley drive transmission are available.

Optional special feet service, to ease planning and installation Beta Marine offer 3D computer aided modeling for the design & the manufacture of bespoke feet to allow direct installation on to your vessels existing engine bearers.

Cutaway Images Are For Illustration Purposes & Not Necessarily Representative

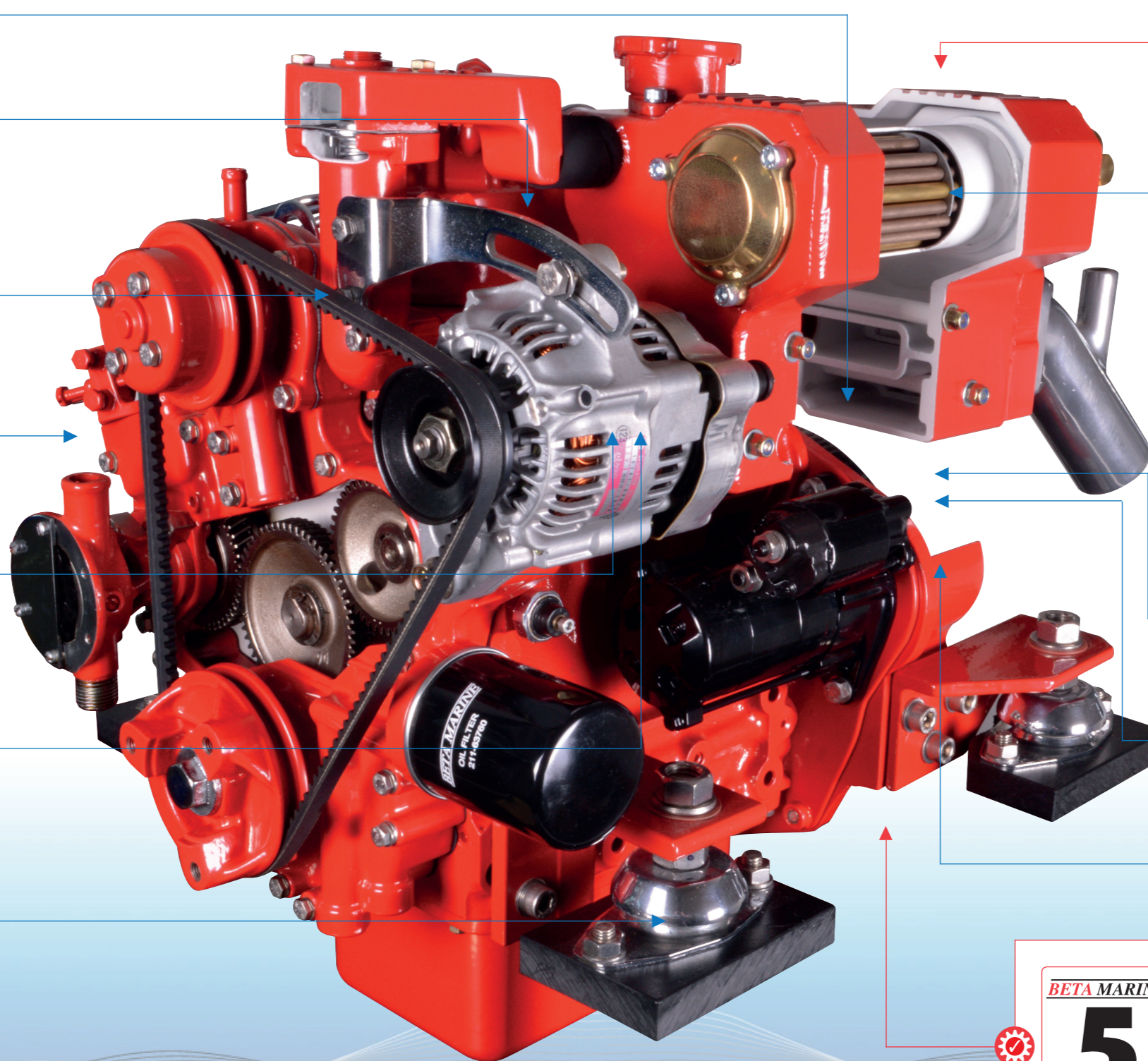

Complete with "ABV" Control Panel & 3m of interconnection cable, "Morse" type engine speed and gearbox control brackets & end fittings. Heavy duty feet and flexible mountings.

- **HEAT EXCHANGER COOLED**, the Beta 14, 16, 20, 25, 30, 38, 43, 50 & 60 are naturally aspirated, whilst the Beta 45T is turbocharged.
- Three vortex combustion with indirect injection for quiet running, low emissions and excellent fuel consumption – Beta 14, 16, 20, 25, 30, 38, 43, 50 & 60.
- ICVS combustion with direct injection for quiet running, low emissions and excellent fuel consumption – Beta 45T.
- Output rotation is clockwise in ahead, viewed from the saildrive end.

Subject to installation criteria & registration, Kubota based engine's used for recreational use benefit from a **5 YEAR 'SELF-SERVICE' ENGINE WARRANTY.**

Beta 45T SD

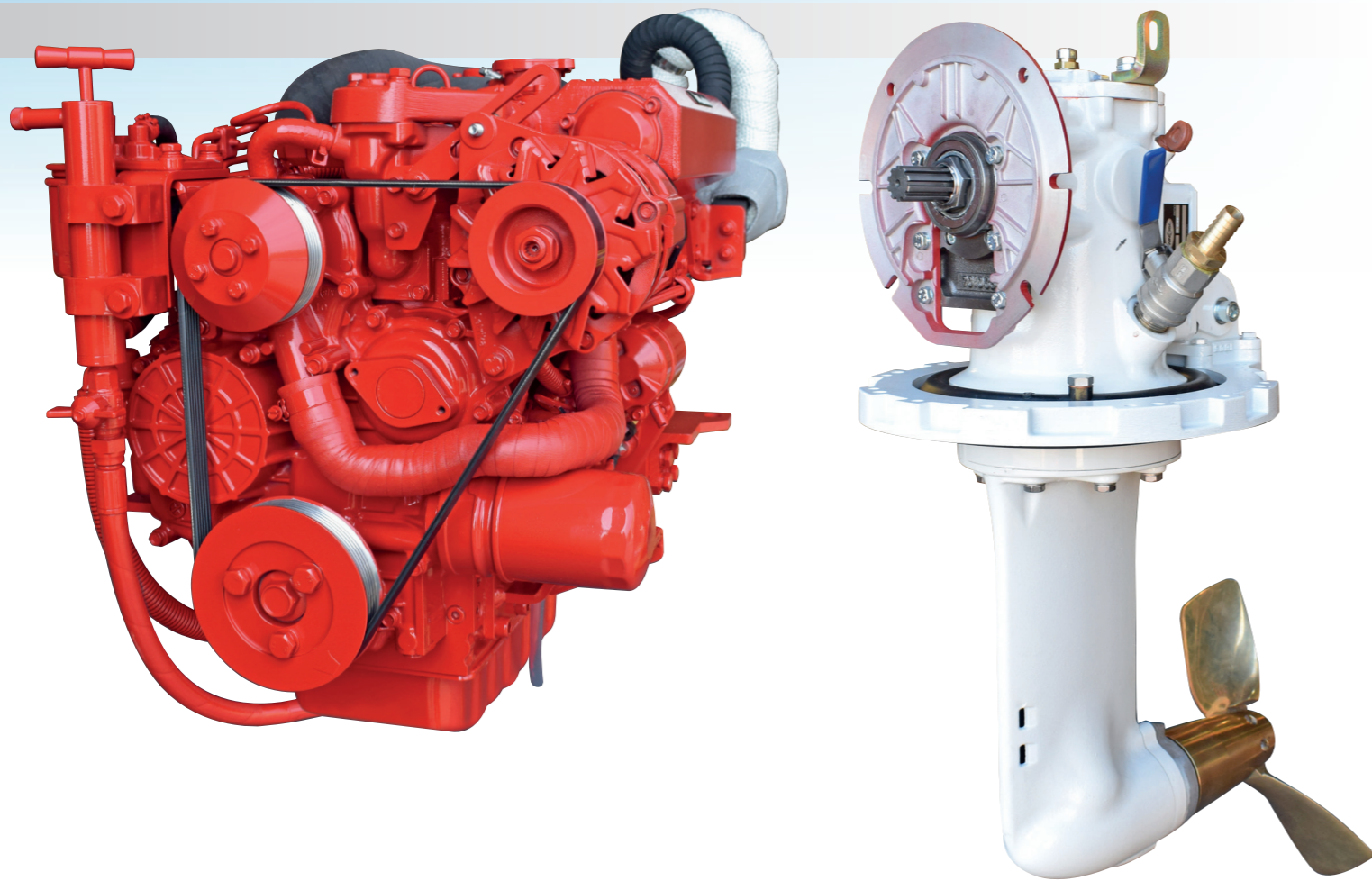

BETA MARINE
5
YEAR 'SELF-SERVICE'
ENGINE WARRANTY

Recreational use only

BETA MARINE
2
YEAR SAILDRIVE
WARRANTY

Recreational use only

**Kubota
Base Engine**

Cylinders	4
Displacement	1498cc
Power	45hp max @ 3,000rpm
Weight	161Kg
Propeller	AIA*

A general guidance for propeller size in inches, based upon 3 blade RH rotation and reduction ratio of 2:1. *For accurate individual advice please provide us with your vessels current full specifications

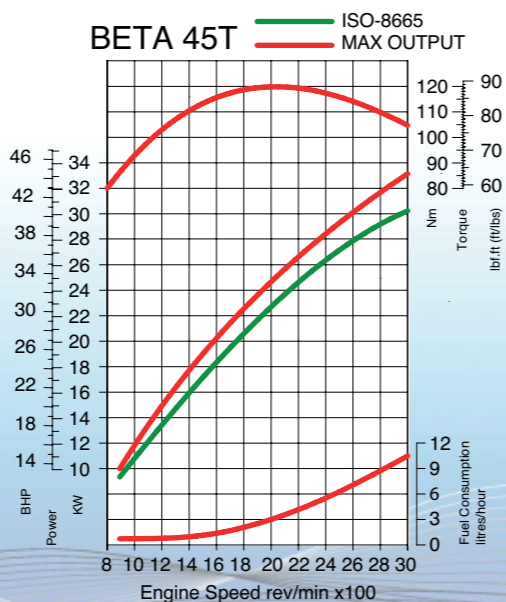

Based on theoretical propeller loading - matched at full speed

Control Panel Options

A Panel	Opt.	B Panel	Opt.
ABV Panel	Std.	BW Panel	Opt.
ABVW Panel	Opt.	C Deluxe Panel	Opt.
		CW Deluxe Panel	Opt.

Saildrive Option

SeaProp 60 Saildrive Leg	Std.
--------------------------	------

Adaptor Kits

Volvo		Bukh	
110S Saildrive	Std.	Bukh Saildrive	Std.
120S Saildrive	Std.	Yanmar	
130S Saildrive	Std.	SD20 Saildrive	Std.

Electrical Options

70 Amp, 12 Volt Alternator	Std.	120 Amp, 12 Volt Secondary Domestic Alternator	Opt.
120 Amp, 12 Volt Alternator in Lieu of Standard	Opt.	125 Amp, 12 Volt Split Charging System	Opt.

Saildrive Dimensions using SeaProp 60

	A	B	C	D	E	F	Weight
Beta 45T SD	228	271	568	784	369	450	211Kg

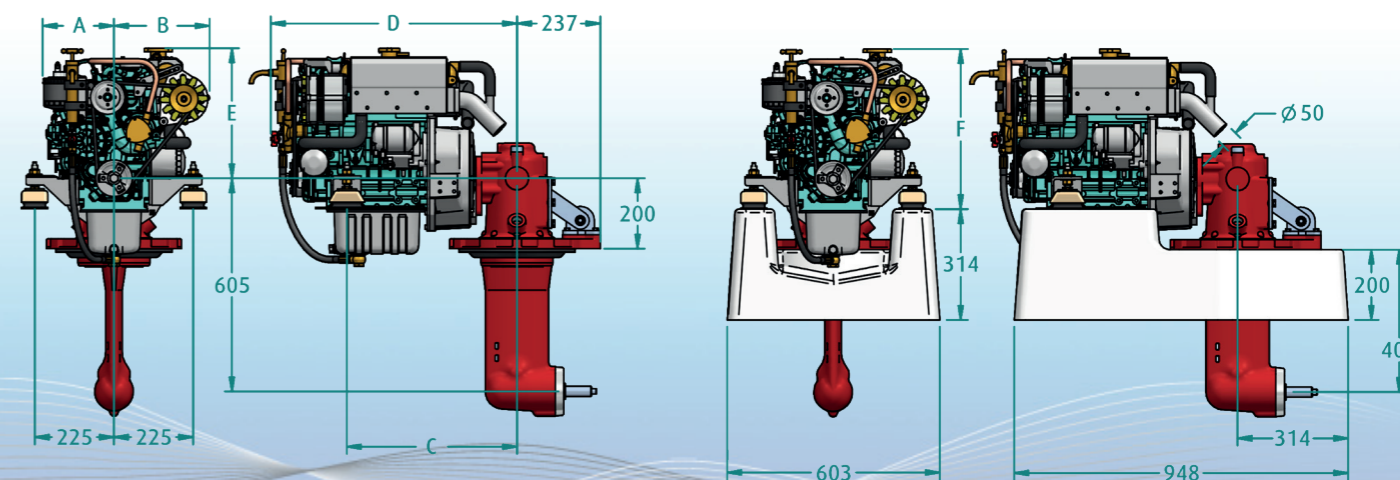

These dimensions are accurate, the drawings are representative: visit our website for all engine / saildrive drawings or contact Beta Marine direct